

# SONIC 2022

## Wideband Multibeam Echo Sounder

### Features:

- Ultra Compact
- Focused Beams to 0.6° x 0.6°\*
- Wideband 170 kHz – 450 kHz
- 700 kHz Option
- Selectable swath sector 10° to 160°
- Swath sector rotation
- Sounding Depth to 400m+
- Embedded processor/controller
- Low weight, volume and power consumption



### System Description:

The Sonic 2022 is a compact wideband shallow water multibeam echo sounder, suitable for a wide variety of general mapping applications.

The Sonic 2022 provides user selectable operating frequencies between 170 kHz and 450 kHz to 1 Hz resolution, and optional 700 kHz, with unparalleled flexibility to trade off resolution and range and controlling interference from other active acoustic systems.

In addition to selectable operating frequencies, the Sonic 2022 provides variable swath coverage selections from 10° to 160°, the ability to rotate the swath sector, as well as roll stabilization. Both the frequency and swath coverage may be selected 'on-the-fly', in real-time during survey operations.

The Sonar consists of the outboard projector and receiver modules, and the inboard Sonar Interface Module (SIM). Third party auxiliary sensors are connected to the SIM. The sonar data is tagged with GPS time.

The sonar operation is controlled from a graphical user interface on a PC or laptop typically equipped with navigation, data collection and storage applications software.

The operator sets the sonar parameters in the sonar control window, while depth, imagery and other sensor data are captured and displayed by the applications software.

Commands are transmitted through an Ethernet interface to the Sonar Interface Module. The Sonar Interface Module supplies power to the sonar heads, synchronizes multiple heads, time tags sensor data, and relays data to the applications workstation and commands to the sonar head.

The receiver head decodes the sonar commands, triggers the transmit pulse, receives, amplifies, beamforms, bottom detects, packages and transmits the data through the Sonar Interface Module via Ethernet to the control PC.

The compact size, low weight, low power consumption 35W and elimination of separate topside processors also make Sonic 2022 *very well suited* for small survey vessel, ROV or AUV operations.

200 kHz	450 kHz	700 kHz
2° x 2°	0.9° x 0.9°	0.6° x 0.6°

Beam widths at selected frequencies (nadir)

# Sonic 2022 Multi Beam Echo Sounder

## Systems Specification:

Frequency	170 kHz – 450 kHz & 700 kHz (optional)
Beamwidth, Across Track	0.6°*
Beamwidth, Along Track	0.6°*
Number of Beams	256
Selectable Swath Sector	10° to 160°
Sounding Depth	400m+**
Pulse Length	15 µs – 1115 µs
Pulse Type	Shaped CW
Ping Rate	Up to 60 Hz
Depth Rating	100 m
Operating Temperature	-10° C to 50° C
Storage Temperature	-30° C to 55° C

## Electrical Interface

Mains	90-260 VAC, 45-65 Hz
Power Consumption	35 W (Sonar Head)
Uplink/Downlink:	10/100/1000Base-T Ethernet
Data Interface	10/100/1000Base-T Ethernet
Sync In, Sync out	TTL
GPS	1PPS, RS-232
Auxiliary Sensors	RS-232
Deck Cable Length	15 m

## Mechanical:

Receiver Dim (LWD)	276 x 109 x 190 mm
Receiver Mass	7 kg
Projector Dim (LWD)	273 x 108 x 86 mm
Projector Mass	3.3 kg
Sonar Interface	280 x 170 x 60 mm
Module Dim (LWH)	
Sonar Interface	2.4 kg
Module Mass	

## Sonar Options:

Snippets/TruePix™ Imagery Output  
 Ultra-High Resolution UHR 700 kHz  
 Switchable Forward Looking Sonar Output  
 Raw Water Column Data Output  
 Integrated Inertial Navigation System  
 Integrated Sediment Profiler  
 Mounting Hardware & Assemblies  
 4000/6000m Immersion Depth Ratings  
 Antifouling Coating Protection

\* Beam width to 0.6° x 0.6° with UHR 700 kHz option  
 \*\*Max sounding depths depend on environmental conditions



## Sonar Interface Module

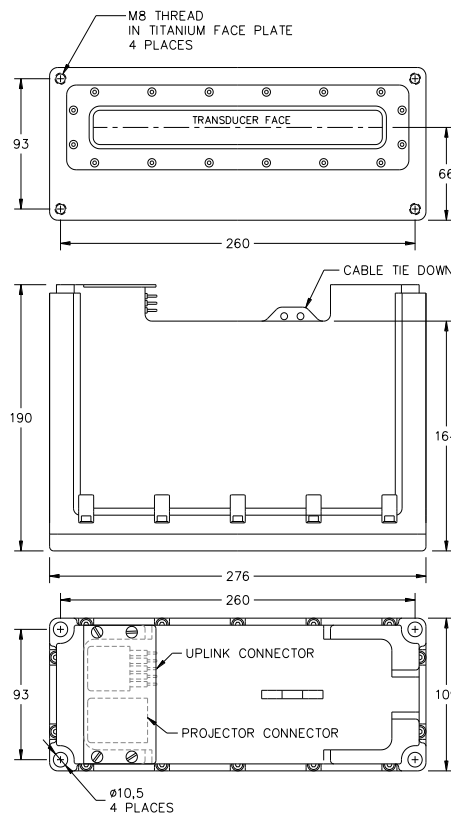

## Sonic 2022 Receiver

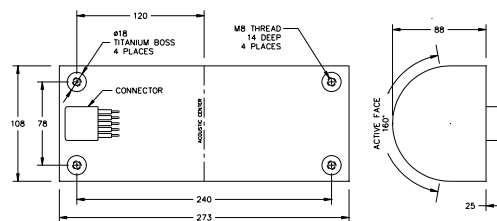

## Sonic 2022 Projector

High Resolution  
Multibeam  
Systems  
for:

Hydrography

Offshore

Dredging

Defense

Research

R2Sonic LLC  
 5307 Industrial  
 Oaks Blvd. Ste 120

T: 512 891 0000

www.r2sonic.com